



SPECK “BÜFFEL” Pumps and Pump Units BS15, BS25, BS40, BS50

1. In General

Every individual pump undergoes a lengthy test-run before leaving our factory. The pump units are approved by the German authorities for technical inspection (TÜV) as well as by the trade and industrial association and comply with EC guidelines for machinery construction.

1.1 Application

SPECK piston pumps are for pumping drinking-water and domestic water and find their use in:

- Single & Multi-storey Houses • Agriculture/Farming • Shipping • Industry • Horticulture

Standard piston pumps and pump units are not to be used for conveying any medium other than water, except if written consent is given by the manufacturer. Special versions are built by us for pumping other media.

1.2 Economy

Speck piston pumps save energy. They only require 0.25 kW/h to pump 1 m³ of water. The comparatively high price of a piston pump is rewarded in time by its low power consumption and long working life.

1.3 Accessories

A belt-guard is available for V-belt drive. The law on technical appliances obligates the manufacturer to always supply a belt-guard, even for pumps without motors. Please note this when ordering.

Declaration of Conformity	Declaration by the Manufacturer
We herewith declare on our own liability	
that the following pump units Pumps with Motor: BS15 BS25 BS40 BS50	that the following Pumps without Motor: BS15 BS25 BS40 BS50
Pump units BS15/150L Pressure Tank BS15/200L Pressure Tank BS15/300L Pressure Tank BS25/200L Pressure Tank BS25/300L Pressure Tank	
comply with pertinent stipulations as per: EC-Machine Guidelines 98/37/EG Applied compatible standards: EN 809 EN 292 T1 EN 292 T2 Electromagnetic Compatibility: 89/336/EWG Applied compatible standards: EN50 081-1 EN50 082-2 Use of Electrical Equipment within specified Voltage Limits: 73/23/EWG Applied compatible standards: EN60 335-1 EN60 335-2-51	
ppa.  (Technical Director)	

Country of Origin: Federal Republic of Germany

SPECK - KOLBENPUMPENFABRIK

Otto Speck GmbH & Co. KG · P.O.Box 1240 · D-82523 Geretsried
 Tel. (08171) 62930 · Telefax (08171) 629399

1.4 Technical Data and Dimensions

“Büffel” Piston Pump

Model		BS15	BS25	BS40	BS50
Flow Rate	l/h	1500	2500	4000	5000
Water Head normal/maximum	m	40/60	40/60	40/60	40/60
Motor Performance at 40m	kW	0,37	0,55	0,75	1,1
Motor Performance at 60m	kW	0,55	0,75	1,1	1,5
No. of V-Belts		2	2	2	2
Profile x Inner Length		10x820	13x975	13x1120	17x1335
Connection Sizes Suction x Discharge	Inch	1 x 1	1 ¼ x 1	1 ½ x 1 ¼	2 x 1 ½
Dimensions approx.	cm	52x22x32	66x23x38	75x26x42	85x36x47
Weight w/o Motor approx.	kg	28	46	66	90

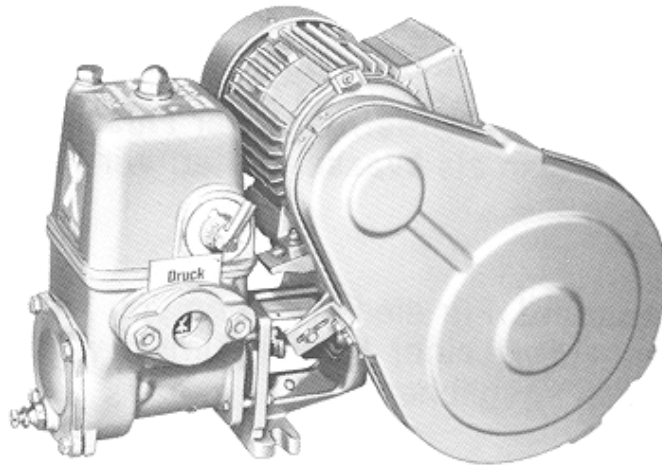

“Büffelpump”

Pump Units - Pump with Horizontal Tank

Pump Model	Size of Tank (litre)	Connection Sizes Suct./Disch. (inch)	Flow Rate (l/h)	Motor Performance (kW)		Dimensions (L x B x H) (approx. cm)	Weight (approx. kg)
				4 bar	6 bar		
BS15	150	1 x 1 1 ¼ x 1	1500	0,37	0,55	105 x 45 x 84	75
	200					107 x 50 x 85	87
	300					140 x 55 x 96	93
BS25	200	1 ¼ x 1	2500	0,55	0,75	107 x 50x 100	105
	300					140 x 55 x 110	110

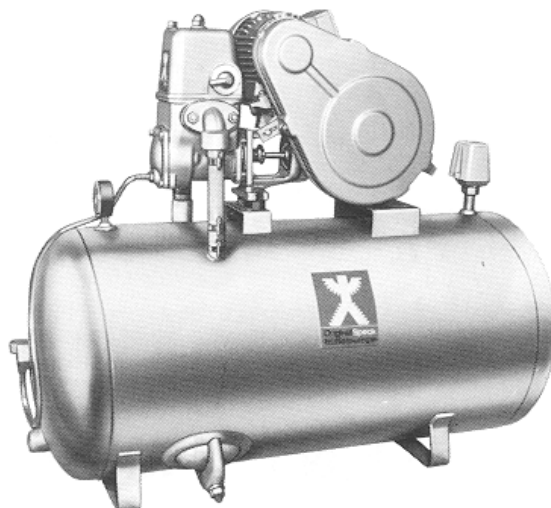

“Büffel” Pump Unit

1.5 Spare Parts List

Part No.	Description	BS15	BS25	BS40	BS50
1	Crankcase	01.0020	01.0148	01.0149	01.0142
1a	Hexagon Screw	21.0290	21.0256	21.0125	21.0258
1b	Stud Bolt	21.0147	21.0045	21.0154	
1c	Hexagon Nut	07.3001	07.2398	07.0988	
2	Gear Cover	03.0012	03.0025	03.0026	03.0027
2a	Hexagon Screw	21.0256	21.0257	21.0258	
2x	Gasket for Gear Cover	06.0440	06.0441	06.0442	06.0443
2b	Vent Plug		07.0614		
2xx	Gasket for 2b		06.0312		
3	Valve Casing Assy w/Stud Bolts + Nuts	00.2384	00.2385	00.2386	00.2387
3a	Suction Flange	20.0031	20.0069	20.0062	20.0087
3b	Discharge Flange	20.0031		20.0032	20.0088
3c	Hexagon Screw	21.0062		21.0188	21.0253
3x	Flange Gasket	06.0387		06.0400	06.0413
400	Gear Assy	00.2012	00.2013	00.2014	00.2015
	Air Chamber w/Safety Valve 4 bar + Filler Plug	00.2396	00.2397	00.2400	00.2401
	Air Chamber w/Safety Valve 6 bar + Filler Plug	00.2425	00.2426	00.2428	00.2429
5	Air Chamber w/o Safety Valve	01.0341	01.0232	01.0235	01.0237
5x	Air Chamber Gasket	06.0085	06.0086	06.0088	06.0089
6	Stuffing Box Casing	01.0021	01.0233	01.0066	01.0534
6a	Stuffing Box Screw	07.2875		07.1291	
6b	Seal Ring	06.0403		06.0411	06.0419
6c	Stuffing Box Insert	-	-	07.1292	07.2226
6d	Gland Packing-Ring	06.1089		06.1136	06.1139
6f	Brass Disc	07.1286		07.1293	07.2227
6x	Stuffing Box Gasket	06.0508	06.0509	06.0510	06.0220
	Stuffing Box complete	00.2255	00.2256	00.2257	00.2258
	Piston Rod Assy with Hexagon Nuts	00.2391	00.5414	00.2393	00.2394
7	Piston Rod	11.0232	11.0233	11.0029	11.0234
7a	Hexagon Nut	07.2398		07.0988	07.1738
7b	Reducing Ring for DUO-Piston	07.1933	-	-	-
8	DUO-Piston Simrit	06.0873	06.0872	06.0871	06.0877
8a	Hexagon Nut	07.4083		07.4084	07.1944
9	Cylinder Assy	00.1916	00.1917	00.1918	00.1919
9a	Hexagon Screw	21.0256	21.0257	21.0258	
9x	Cylinder Gasket	06.0777	06.0117	06.0525	06.0118
10	Cylinder Cover	03.0014	03.0040	03.0144	03.0145
10a	Hexagon Screw	21.0366	21.0256	21.0366	
10x	Gasket for Cylinder Cover	06.0589	06.0590	06.0591	06.0119
11	Suction Valve Assy	00.2170	00.2071	00.1291	00.2346
111	Suction Valve Stem	07.2539		07.1220	
112	Suction Valve Seat (Brass)	07.0021	07.0023	07.0065	07.1158
118	Self-Locking Hexagon Nut	07.0669		-	-
12	Discharge Valve Assy	00.2171	00.2072	00.1292	00.2347
121	Discharge Valve Stem	07.2540		07.1219	
122	Discharge Valve Seat (Brass)	07.0020	07.0022	07.2608	07.1157
119/129	Suction and Discharge Valve Retainer	07.2538		-	-
113/123	Suction / Discharge Rubber Valve Plate	06.1065	06.1066	06.0857	06.0858
114/124	Spring Tension Disc (large)	-	-	07.1939	07.1361
115/125	Valve Spring	-	-	07.3662	07.0025
116/126	Spring Tension Disc (small)	-	-	07.1360	
117/127	Cotter Pin	-	-	07.1215	
11x/12x	Gasket for Valve Seat	06.0391	06.0405	06.0416	06.0518
13	Valve Bridge Stud Bolt	21.0002	21.0194	21.0046	21.0051
13a	Hexagon Nut	07.3001	07.2398	07.0988	
13b	Disc	07.2904	-	-	-
14	Valve Bridge	03.0268		03.0042	03.0044
15	Plug		07.0487		
15x	Gasket		06.0054		
16	Plug		07.0487		
16x	Gasket		06.0054		
17	Connecting Rod Assy	00.2004	00.2005	00.2006	00.2007
17a	Tension Screw for Connecting Rod	21.0103		21.0104	21.0105
17b	Sleeve for Connecting Rod	05.0066	05.0067	05.0068	05.0069
17c	Hexagon Nut	07.2618		07.2022	07.1995

Part No.	Description	BS15	BS25	BS40	BS50
18	Pump V-belt Pulley	19.0001	19.0014	19.0008	19.0049
18a	Hexagon Screw w/Pointed Extension	21.0161	21.0110		
18b	Motor V-Belt Pulley	19.0051	19.0050	19.0038	19.0009
18c	Pointed Threaded Stud		21.0113		21.0114
19	Motor Mounting Rail left	23.0001	23.0018	23.0016	
192	Motor Mounting Rail right	23.0119	23.0018	23.0120	
19a	Hinge Pin with Thread	11.0332	11.0331	11.0334	
19b	Hinge Pin	11.0235	11.0082	11.0335	
19c	Hexagon Screw	21.0116	21.0115	21.0120	
19d	Insulation Sleeve	07.0161	07.0162		
19e	Hexagon Nut	07.3001	07.2398		
191	Hexagon Screw	21.0290	21.0256		
	Motor Rocker Assy	00.2442	00.2035	00.2443	00.2444
20/21	Diaphragm Safety Valve Assy w/Seat 4 bar	00.1303	00.1305		
20/21	Diaphragm Safety Valve Assy w/ Seat 6 bar	00.1304	00.1306		
20x	Gasket for Safety Valve Casing		06.0395		
21	Safety Valve Seat Assy	00.3205	00.3208		
21x	Gasket for No 21	06.0312	06.1020		
22	Acorn Nut for Air Chamber	07.0485	07.1257	07.0485	
22a	Air Chamber Stud Bolt	21.0044	21.0195	21.0042	21.0043
22b	Disc	07.1259	07.1211	07.1259	
23	Crosshead	17.0014	17.0015	17.0017	17.0002
23a	Crosshead Pin	11.0357	11.0358	11.0359	11.0360
24	Oil Indicator with Nut	-	00.1953	-	-
	Oil Level Gauge/Oil Dipstick	00.1959	-	00.1938	
24x	Gasket	-	06.0312		
25	Main Bearing Sleeve	05.0032	05.0033	05.0039	05.0034
26	Oil Splash Cap	03.0100	03.0118	03.0098	03.0167
27	Oil Scraper	06.0408	06.0417	06.0470	
28	Oil Filler Plug w/o Thread	07.0489	07.1319	07.1320	
29	Snifting Valve G3/8 with Stop Screw		00.1939		
	Snifting Valve G3/8 with Hose Nipple		00.1940		
29a	Snifting Valve Lip		06.0398		
29x	Gasket for Snifting Valve		06.1020		
30	Bearing Cover open	03.0185	03.0184	03.0028	
30a	Bearing Cover closed	03.0013	03.0194	03.0182	
30b	Hexagon Screw	21.0315	21.0125		
30x	Gasket for Bearing Cover	06.0447	06.0448	06.0449	
301	Radial Shaft Seal	06.0418	06.0399	06.0409	
302	Grooved Ball Bearing	05.0111	05.0151	05.0110	05.0156
303	Spacer Ring	07.1302	07.1307	07.1321	
304	Spacer Ring	07.1302	07.1307	07.1450	07.1540
304a	Woodruff Key		07.1200		
33	Plug	07.0751	07.2803		
33x	Gasket	06.0312	06.1020		
34	V-Belt	07.1303	07.1308	07.1312	07.1322
35	Main Bearing Shaft	11.0018	11.0019	11.0013	11.0014
35a	Cover for Main Bearing Shaft	03.0188	03.0189	03.0190	
35b	Notched Nail	-	-	07.1977	
35x	Gasket for Main Bearing Shaft	06.0746	06.0747	06.0436	
405	Fitting Disc for Connecting Rod 0.5mm	07.1304	07.1313	07.1925	
405a	Fitting Disc for Connecting Rod 0.2mm	07.1305	07.1314	07.1924	
xx	Complete Set of Gaskets	00.2453	00.2454	00.2455	00.2456
	Crankcase Assy	00.2753	00.2754	00.2755	00.2756
	Crankcase Assy, exchanged	00.2757	00.2758	00.2759	00.2760
	Pump Head Assy with Safety Valve 4bar	00.2617	00.2618	00.2619	00.2620
	Pump Head Assy with Safety Valve 6bar	00.2745	00.2746	00.2747	00.2748
	Air Volume Control		00.2479		
	Air Hose 0.9 m		32.0006		
	Drain Cock G1/4		00.1941		
	Gasket for Drain Cock		06.0312		

1.5.2 Exploded View

N.B. The self-locking nut in the suction valve should only be used once. Please keep this in mind when ordering spare parts!

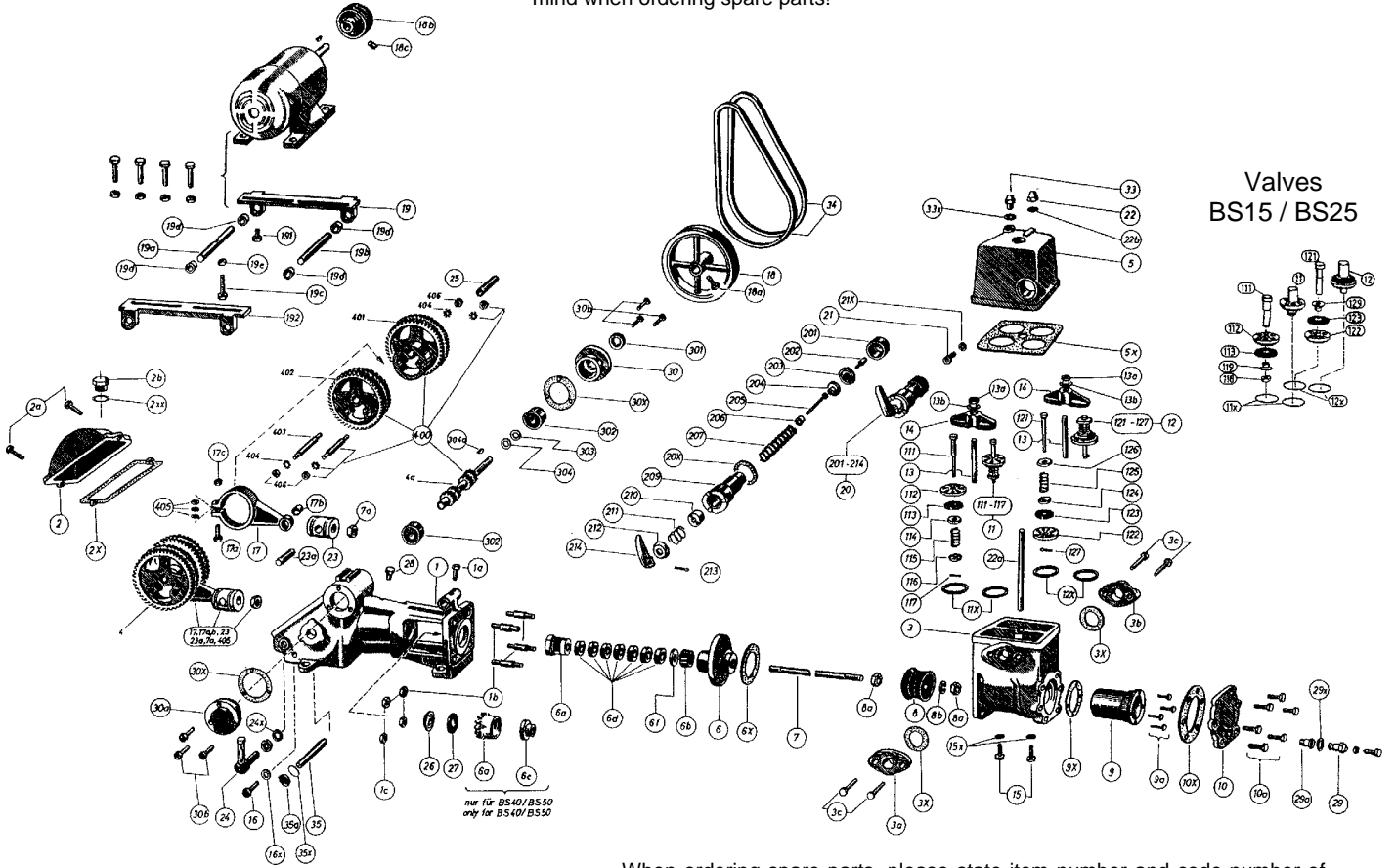

When ordering spare parts, please state item number and code number of the part required as well as the pump model and year of construction which can be found on the name plate.

2. Safety

This Operation Manual gives basic instructions which are to be observed during installation, operation and maintenance of the pump. It is therefore imperative that this manual be read by the responsible personnel/operator prior to assembly and commissioning. It is always to be kept available at the installation site. It is not only the general safety instructions contained under this main heading 'Safety' that are to be observed, but also the specific information provided under the other main headings.

2.1 Kennzeichnung von Hinweisen in der Betriebsanleitung

Safety instructions given in this manual, non-compliance with which would affect safety, are identified by the following symbol:



see DIN 4844 - W9



or where electrical safety is involved, with

see DIN 4844 - W8

Safety measures which can cause damage to the machine if not adhered to, are marked

Important!

It is imperative that signs affixed to the machine, e.g.

- arrow indicating the direction of rotation
- symbols indicating fluid connections

be observed and kept legible.

2.2 Qualification and Training of Operating Personnel

The personnel responsible for operation, maintenance, inspection and assembly must be adequately qualified. Scope of responsibility and supervision of the personnel must be exactly defined by the plant operator. If the staff does not have the necessary knowledge, they must be trained and instructed, which may be performed by the machine manufacturer or supplier on behalf of the plant operator. Moreover, the plant operator is to make sure that the contents of the operating manual are fully understood by the personnel.

2.3 Hazards in the Event of Non-Compliance with the Safety Instructions.

Non-compliance with the safety instructions may produce a risk to the personnel as well as to the environment and the machine, and may result in a loss of any right to claim damages.

For example, non-compliance may involve the following hazards:

- Failure of important functions of the machine/plant
- Failure of specified procedures of maintenance and repair
- Exposure of people to electrical, mechanical and chemical hazards
- Endangering the environment owing to hazardous substances being released.

2.4 Safety at Work

The safety instructions contained in this manual, the relevant national accident prevention regulations and any other service and safety instructions issued by the plant operator are to be observed.

2.5 Safety Instructions Relevant for Operation

- If hot or cold machine components involve hazards, they must be guarded against accidental contact.
- Guards for moving parts (e.g. coupling) must not be removed from the machine while in operation.
- Any leakage of hazardous (e.g. explosive, toxic, hot) fluids (e.g. from the shaft seal) must be drained away so as to prevent any risk to persons or the environment. Statutory regulations are to be complied with.
- Hazards resulting from electricity are to be prevented (see, for example, the VDE Specifications and the by-laws of the local power supply utilities).

2.6 Safety Instructions Relevant for Maintenance, Inspection and Assembly Work

It shall be the plant operator's responsibility to ensure that all maintenance, inspection and assembly work is performed by authorized and qualified personnel who have adequately familiarized themselves with the subject matter by studying this manual in detail.

Any work on the machine shall only be performed when it is at a standstill.

Pumps and pump units which convey hazardous media must be decontaminated.

On completion of work, all safety and protective facilities must be re-installed and made operative again.

Prior to restarting the machine, the instructions listed under 'Operation' are to be observed.

2.7 Unauthorized Alterations and Production of Spare Parts

Any modification to the machine may only be made after consultation with the manufacturer. Using spare parts and accessories authorized by the manufacturer is in the interest of safety. Use of other parts may exempt the manufacturer from any liability.

2.8 Unauthorized Modes of Operation

The reliability of the machine delivered will be only guaranteed if it is used in the manner intended, in accordance with clause 1 'In General' of this manual. The limit values specified in the data sheet must under no circumstances be exceeded.

Pending Standards and other Data

DIN4844 Part 1:	Safety descriptions and safety signs W8 - supplement sheet 13
DIN4844 Part 1:	Safety descriptions and safety signs W9 - supplement sheet 14

3. Transport and Storage

Pumps and pump units must not be stored for any length of time in a humid place or where temperatures are below zero. The storage room should be airy as moisture will damage the motor and thus void the warranty. Pumps are packed for transportation in cardboard boxes or on pallets. When unpacking, check for damage.

4. Description

4.1 "Pumpmeister"

SPECK piston pumps of the "Büffel" pump series have a thoroughly proven double-helical precision gear of unsurpassed working quietness and service life.

When turned in the correct direction, the gear is lubricated by an oil-dip bath with flooded crosshead. Suction and discharge connections are on the valve casing and are interchangeable.

Valve casing, air chamber, stuffing box and cylinder cover are of grey cast iron (GG20).

The brass suction and discharge valves (2 of each) are made easily accessible by removing the air chamber. The suction/discharge line does not have to be removed. The solid conrod is of bronze (G-CuSn10). The brass cylinder sleeve can be removed using set-screws. The duo-piston is of NBR rubber. Teflon-impregnated packing rings are used for the piston rod sealing in the stuffing box. A TÜV (German authorities for technical inspection) approved diaphragm safety valve protects against inadmissible excessive pressure. Water will not flow out of the pump if the pressure is too high. Surplus water is circulated within the pump, back to the suction side.

4.2 "Büffelpumpe" Pump Unit

SPECK pump units are "Büffelpumpe" piston pumps on galvanized horizontal pressure tanks, complete systems ready for connection. They are equipped with an electric motor, V-belt pulleys, V-belts, belt-guard, automatic air volume control, pressure switch, pressure gauge and a built-in safety valve.

The automatic air volume control installed in the pressure tank of the unit automatically ensures the correct ratio between water content and the necessary air cushion.

If the horizontal tank is half full, the valve of the automatic air volume control, activated by the float, opens and the pump begins conveying both air and water into the tank.

A suction head of approx. 4-6 m is required so that the pump can draw in air in the proper manner.

When water leaves the tank, the pressure in the tank drops until the pressure eventually sinks to the automatic switch-on point at which the pressure switch turns on the motor/pump. The amount of water which left the tank is then pumped in again until the switch-off level is attained. This procedure repeats itself again and again at irregular intervals, depending on how often and how much water is withdrawn from the tank.

4.3 Values for Pressure Switch Adjustment

Pump Unit 4 bar:	Switch-On Pressure:	2 bar
	Switch-Off Pressure:	3.5 bar
Pump Unit 6 bar	Switch-On Pressure:	3 bar
	Switch-Off Pressure:	5.5 bar

5. Set-Up and Installation (only to be done by skilled workmen)

5.1 Pump Unit

The complete pump unit with horizontal pressure tank is supplied ready-assembled. A special foundation is not necessary. The tank can be fixed to the foundation by 4 spacer blocks.

Important!

The room must be frost-proof and dry. It should also be well aired in order to prevent undesirable moisture condensate forming on the unit. Moisture damages the motor.



To protect against accidents, each pump is to be equipped with a belt-guard which conforms to trade union and/or general safety rules.



The pump-motor must be protected by a correctly adjusted motor protector.

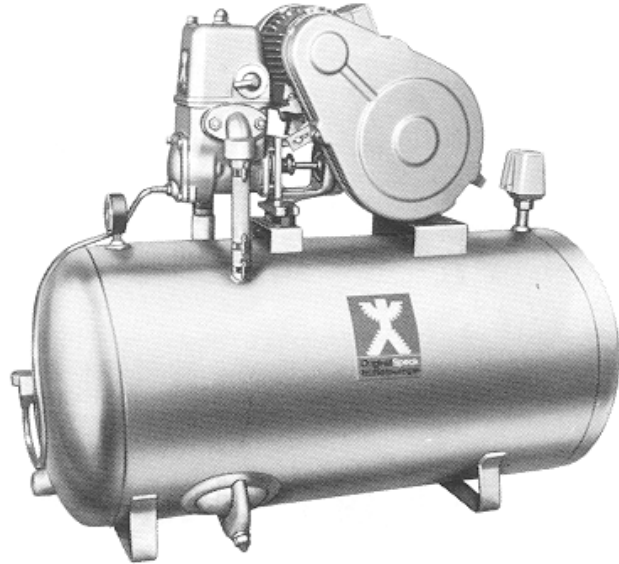

„Büffel“ Pump Unit: Pump and motor, horizontal pressure tank and belt-guard

5.2 Pump Unit with Vertical Tank

Assembly:

Contrary to the complete TÜV-approved pump units with horizontal tanks which are supplied ready assembled, the units with vertical tanks have to be set up and installed by a plumber on location. They function the same as the ready assembled units. However, we wish to point out that an automatic air volume control can also be installed in a vertical tank when the unit is being set up (s. fig. 113). Directions (D10671) for installing the automatic air volume control are available upon request.

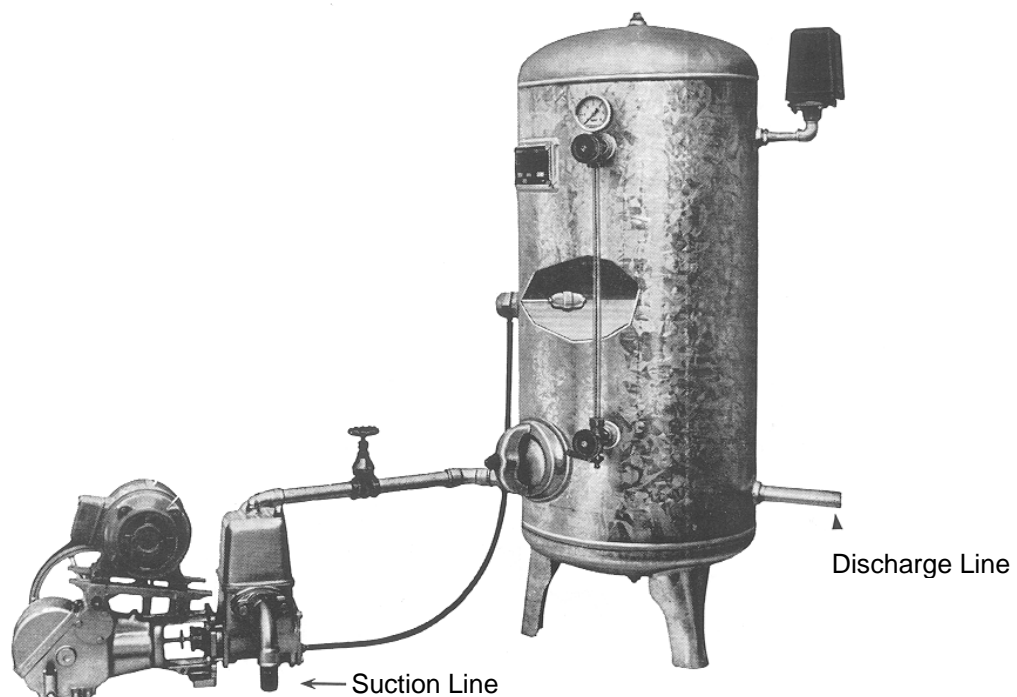

Fig. 113 „Büffel“ pump unit with vertical tank

5.3 „Büffel“ Pump

Single “Büffel” piston pumps are screwed on to a brick or concrete base and secured with foundation bolts. No particular foundation is required for vertical tanks. Pumps without a base plate and therefore without vibration insulation should be mounted on to a piece of anti-vibration material placed between the pump and ground.

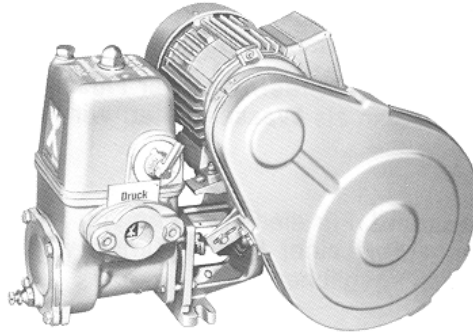

Fig. 112 „Büffel“ pump

5.4 Suction Line for Pump Units and “Büffel” Pumps

Important! Perfect functioning of the pump depends largely on well laid-out suction lines. In order to prevent air-pockets, the suction line should rise gradually from the well to the pump, or should at least be laid horizontally. It must be absolutely seal proof and the inner diameter should at least be as large as the connection on the pump. Only bows are to be used, no elbows. It is advisable to install a foot valve or an intermediate valve in the case of a closed filter well. If suction lines are longer than 30 m, a suction air chamber is to be installed directly in front of the pump. If vertical tanks are used (fig. 113), it is advisable to support heavy suction lines so that their weight does not pull on the pump.

5.5 Suction Head

Important! The total gauged suction head which is the height between the water level and the pump plus loss of friction in the pipe and possible filter resistance, is not to exceed 7.5 m, not forgetting that in dry seasons the water level in the well may be lower than usual. In the case of short suction lines or a suction head of below 2m, or if input pressure is present, a shut-off valve (not a tilted seat-valve) must be installed in front of the pump. This shut-off valve can be adjusted with greater accuracy to the required suction head, ensuring the avoidance of water-hammer.

5.6 Intake Pressure - Pump Unit as Booster Set

Important! If the inlet pressure is more than 0.3 bar (3 m), it is advisable to install a pressure-free tank with float valve. If this cannot be done, a shut-off regulator valve must under all circumstances be installed in the feed line. A vacuum of 4-6 m has to be provided if the automatic air volume control is to function properly. If the pump hammers, install a suction air chamber (approx. 7.5-15 ltrs) in the feed line. A shut-off valve is at all events necessary in a suction line with intake pressure so the pump can be opened for servicing.

5.7 Discharge Line - Refers only to installation of pump units with vertical tanks or pumps alone

Important! If possible, the line should rise gradually upwards from the pump to the tank or at least be horizontal - it should never slope downwards. Only use curved joints, elbows may only be used after the tank.

5.8 Umtausch der Saug- und Druckanschlüsse

(Does not apply to units with horizontal tanks)

The suction and discharge sides of SPECK “Büffel” pumps can be interchanged by converting the suction and discharge valves. This often saves inconvenient installation of suction and discharge lines. Install clean valve seals and make sure the valves sit properly.

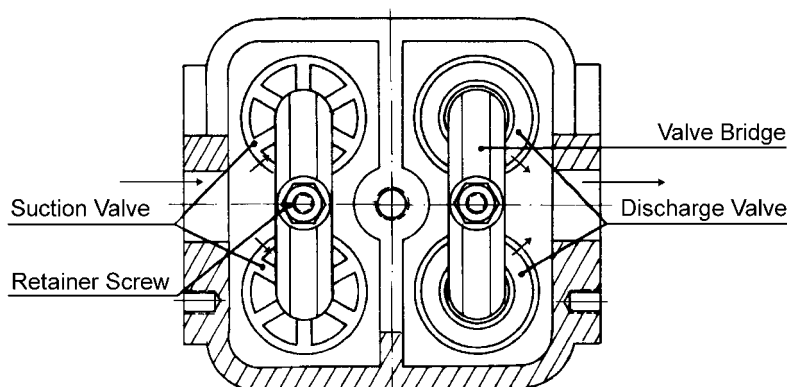

After suction and discharge valves have been exchanged, the air chamber must be turned around 180° so that the safety valve is always located on the discharge side.

Fig. 114

6. Operation

6.1 To Fill Pump with Oil

Important! Fill crankcase with an SAE30 quality oil through opening above crosshead (23).

BS15	BS25	BS40	BS50
0,2 litres	0,3 litres	0,8 litres	1,0 litres

6.2 To Fill Pump with Water

Important! Fill up pump head with water by pouring the water in via filler plug (33) At the same time, turn the pump V-belt pulley (18) manually in the direction of the arrow. In the case of long suction lines, fill right up to the foot valve/intermediate valve (see 5.4)

6.3 Motor Alignment and Electrical Connection

Using a ruler, make sure the pump pulley and motor V-belt pulley (18/18b) are in line with each other. The motor could have been shifted during transport and if the pulleys do not align precisely, the belts will wear out quickly.



Electric motors must be connected as per circuit diagram which can be found in the terminal box of the electric motor. This work is to be carried out by suitably qualified persons.

6.4 Fittings

Open shut-off fittings and taps in the discharge line so that the air in the pipe system can escape.

6.5 To Switch on Motor

Important! Check the direction of rotation. Reverse polarity if the motor is running in the wrong direction. Close the shut-off fitting only after water has begun being pumped, after the suction line and pump are vented (clearly visible through transparent tube – fig. 111/II) and after water has come out of the tap. Depending on the size of the tank, it takes between 5-15 minutes until the tank is full and the pressure switch switches off at either 3.5 bar or 5.5 bar.

6.6 To Let Water Out

Turn tap on and let water out. Pressure drops eventually to 2 or 3 bar respectively and the pump switches on again automatically. Only a few air bubbles should now be visible in the suction line, otherwise there is reason to believe that the suction is not correctly sealed. Approximately 2000 litres of water per hour flow out of an open G1/2 tap at 3 bar pressure.

6.7 On/Off Switching Pressure

(for 4 and 6 bar units)

Important! The pump unit and the built-in safety valve have been approved by the German Association for Technical Safety (TÜV). The safety valve is adjusted to 4 or 6 bar according to TÜV regulations. The pressure tank is also approved for max. pressure of 4 or 6 bar. The pressure switch must therefore be adjusted to a maximum pressure of 3.5 bar / 5.5 bar otherwise it will activate the safety valve. To readjust switch-on / switch-off pressure, see instructions on pressure-switch (Fig. 111/IV).

Switching Stages:

4 bar Pump Unit	Switch-On Pressure	2 bar
	Switch-Off Pressure	3,5 bar
6 bar Pump Unit	Switch-On Pressure	3 bar
	Switch-Off Pressure	5,5 bar

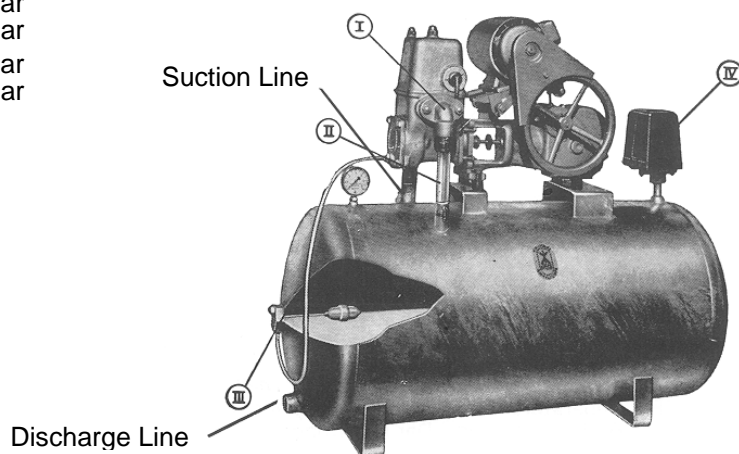

Fig. 111 Büffel Pump Unit

7. Maintenance and Servicing

7.1 Lubrication

Important! The gear is lubricated automatically provided the pump revolves in the correct direction. Oil level should be checked every three months and topped up if necessary till oil can be seen through the indicator glass (24). First oil change after 3 months operation and then every 2 years, or every 6 months if the pump is running continuously. This is done by unscrewing the indicator (24) or screw (16) and draining out the old oil. Clean out the crankcase thereafter (removing gear cover [2]) and refill with fresh oil as described under paragraph 6.1.

7.2 Stuffing Box

Important! The compact stuffing box is made of Teflon-impregnated packing rings and a seal ring and requires practically no maintenance at all. If the stuffing box should drip, tighten stuffing box nut (6a) carefully by approx. one 1/2 turn. If this does not help, the whole stuffing box (6d) must be replaced. In this case, the seal ring (6b) should also be changed. Pay careful attention when installing seal ring: the lip ring spring must face the piston.

7.3 V-Belts

Important! V-belt (34) should not be overtensioned. However, it is advisable to tighten belts up again after a few days of operation. When renewing V-belts on multi-belt drive, the complete set has to be replaced.

7.4 Gear

Important! The original SPECK high pressure "Büffel" pump has a double-herringbone (helical) precision gear with a bronze connecting rod. If the directions under paragraph 7.1 for lubrication are followed, further maintenance is practically unnecessary. Only the connecting rod alone might need readjusting after approx. 1 year when it has been run in and if a possible knocking sound can be heard. To do this, unscrew self-locking hexagon nut (17c), screw out inner hexagon tension screw and remove 0.1 - 0.5 mm of spacer shims (405) as required from connecting rod joint. Screw back tension screw (17a) tightly against hexagon nut. After approx. 1 hour of operation, check whether the connecting rod has not been overadjusted and is running hot.

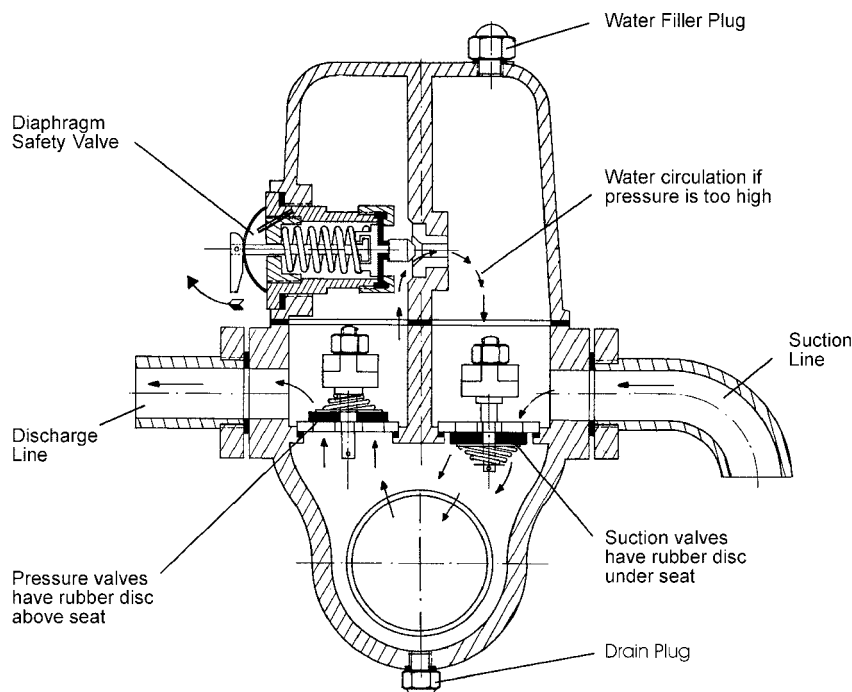

7.5 Air Replenishment - for Cold Water Operation Only

Important! The pump will run smoothly and silently if there is air in the air chamber. This air cushion is regulated via the sniffling valve. At the same time air is pumped into the pressure tank. The more air there is in the pressure tank, the more water can be discharged before the pump switches on again (see paragraph 4.2).

If the automatic air volume control has to be repaired, kindly ask for our instruction sheet D10672. The unit itself is only available as a complete set.

8. Failures and Remedies

If you have trouble with your pump, you may be able to help yourself by reading the tips we give you below. If you cannot find the reason for the trouble, call a plumber or write to us, not forgetting to mention the pump model and its serial number.



Prior to doing any work on the pump, switch off the electricity and make sure that the pump is idle and the pressure at zero.

8.1 Little or no water at all is being pumped

Possible Reason	Remedy
a) Pump is running but delivers no water even though it is filled properly.	Remove air chamber (5) and loosen rubber valve discs (113/123) which have probably got stuck if the pump has been stored for a long time.
b) Not sufficient water in the pump.	Refill pump as explained in 6.2 and at the same time turn the pump several times pouring in water little by little till there are 2-4 litres in the pump. Screw on filler plug (33) again and seal carefully. More water may be necessary if the suction line is very long or the suction head very high.
c) Suction head too high / suction line too long.	Measure difference between water level and pump flange connection (fig. 111/I). Compare loss of friction in long pipes with table (available upon request) and add the difference in height.
d) Suction line is not seal-proof.	After the pump has been running for a while, check whether air bubbles can be seen through transparent hose (Fig. 111/II) above elbow on tank. If so, press out air, find leak and make it seal-proof.
e) Soiled or worn-out valves	Pebbles, hemp, shavings etc. coming from new wells often get absorbed into the pump so the air chamber (5) has to be removed and the valves checked. Loosen nuts above valve bridge. Remove valve bridge and any crust which may be on it. Valves are not screwed in. If they are stuck, press them loose with the handle of a hammer. The valve seat seal is under the valve - make sure that the seat is clean. Rubber valve discs (113/123) may have to be replaced if the pump is old.
f) Stuffing box is not seal-proof.	Tighten up nut (6a) a little. If this does not help, replace packing rings (6d) and possibly seal rings (6b) as well. Do not use hemp, we use Teflon-impregnated packing rings.

8.2 Pump Knocks

Possible Reason	Remedy
a) There is no air cushion in the air chamber	Make sure that the air volume control (Fig.111/III) is working properly. The snifting valve should hiss when the pump is running. Check whether rubber lip (29a) is dirty or clogged. Air could be escaping through screw on filler plug, therefore check by covering sealing surfaces of air chamber and filler plug with a soap solution.
b) Pre-pressure in pump	Water level in pump/air chamber is too high because snifting valve has not absorbed enough air. Install regulator in suction line (s.5.5/5.6). Pump should run with about 5 metre vacuum ensuring that sufficient air is pumped.
c) Pump suction head is very low	Same applies here as explained under b). A vacuum must be provided by means of a regulator so that sufficient air will be pumped.
d) High suction head - long suction line	Install a suction air chamber as per 5.4 and ensure sufficient ventilation. Make sure there is enough water in the well, e.g. after a dry season.
e) Conrod bearings in pump deflect	You can not always determine the reason for knocking by ear, so you have to turn the V-belt pulley (18) backwards and forwards to determine any clearance between bearing and conrod. Repairs to the gear are best done by a skilled tradesman.
f) The pump V-belt pulley deflects and does not sit properly on the crankshaft	As described under e).
g) One of the ball bearings is defective	As described under e).

8.3 Pump switches on when very little water is discharged and switches off immediately the tap is turned off

Possible Reason	Remedy
The air cushion is not filled up sufficiently. During initial operation, there may not have been enough air pumped into the tank or the air the pump has pumped into the tank is escaping somewhere (pressure switch, pressure gauge, air volume control, pump connections, transport damage).	If snifting valve and air volume control are working properly (111/III) and there still is not enough air in the tank, coat all threaded connections on tank with a soap solution to determine where it is leaking. It could also be that the pressure switch (111/IV) is not air-tight.

8.4 Pump switches on automatically although taps are turned off

Possible Reason	Remedy
a) A tap is leaking or air is escaping from the tank.	Check by switching off the complete unit overnight. Turn off all taps and check whether the pressure drops.
b) Leaky valves or leaky safety valve cause water to run back into the well.	Open pump and check whether the valves are sealing properly.
c) Foot valve/intermediate valve in the suction line leaks. Water runs back into the well.	Switch pump off and lift safety valve at 3.5/5.5 bar. If foot valve/intermediate valve is working properly, no return flow should be heard (or seen at pressure gauge of tank) immediately after lever (214) has been lifted.

8.5 Air escapes from tap when water is let out

Possible Reason	Remedy
a) There is too much air in the tank. The well water is probably very gassy and a lot of air separates into the tank. If the suction line is very long and the suction head high, it could be that too much air is being pumped.	In this case, it is advisable to disconnect the pipe of the air volume control for a while or install a special rubber lip with a very small hole into the snifting valve.
b) Suction line leaks.	Find leak and seal it.

8.6 Water is pumped easily till shortly before switch-off pressure is reached and then the pump continues to run but does not pump any water because it can't reach the final pressure

Possible Reason	Remedy
This can happen if too much air is pumped through the air volume control when suction lines are very long and suction head very high. This often occurs when the suction line is not absolutely seal-proof and allows even more air to get into the pump. It can also be caused by worn out rubber valve plates, worn out cylinder or pistons.	We recommend either installing a rubber lip with a very small hole or put the air volume control in the suction line out of action from time to time. Replace rubber valve plates (113/123). Check whether piston or brass cylinder are worn out and replace as necessary.

8.7 Water leaks at Air Volume Control

Possible Reason	Remedy
Rubber lip of snifting valve (29) is damaged.	Replace rubber lip (29a).

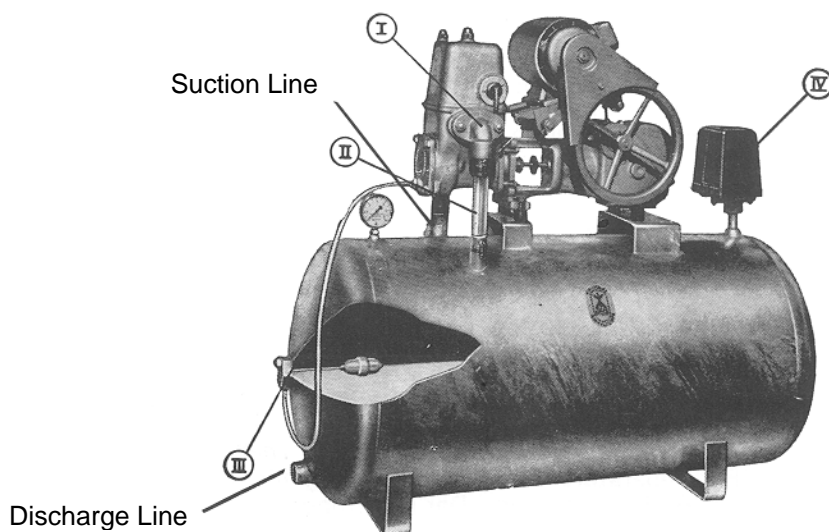

Fig. 111 „Büffel“ Pump Unit